

SNAP 2/3/4

Micro tool for front and back chamfering
in one operation from $\varnothing 2\text{mm}$.

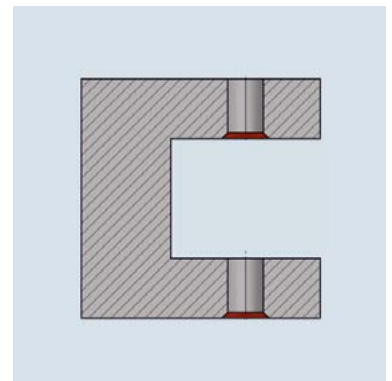

SNAP2 tool $\varnothing 2.0\text{mm}$ to 2.9mm

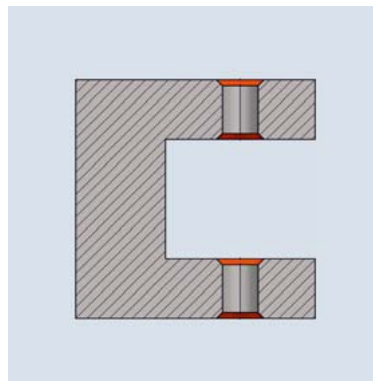
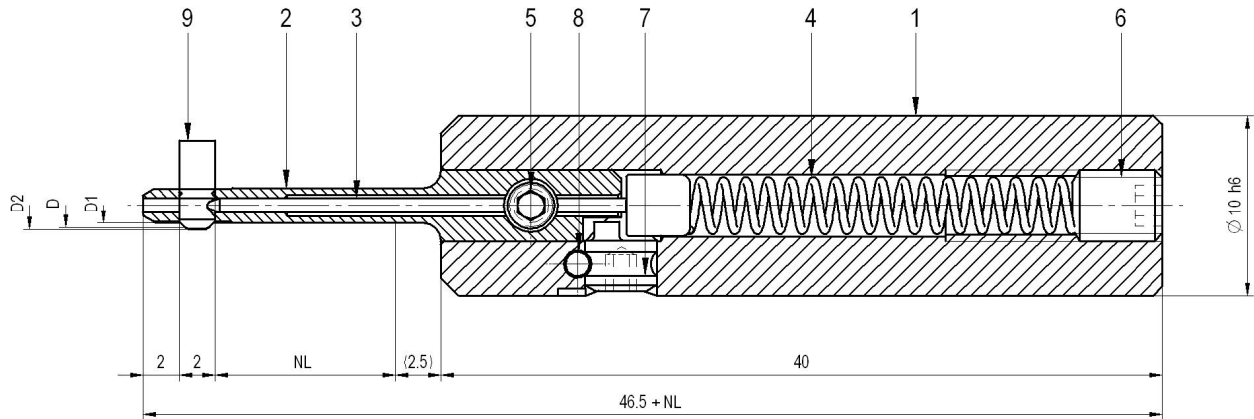

Tool table					
Bore- \varnothing	max chamfer- \varnothing	Tool- \varnothing	Maximal- \varnothing	complete tool without blade	
d	D	D1	D2	NL 10mm	NL 20mm
2.0	2.4	1.95	2.6	SNAP2/2.0/10	SNAP2/2.0/20
2.1	2.6	2.05	2.8	SNAP2/2.1/10	SNAP2/2.1/20
2.2	2.6	2.15	2.8	SNAP2/2.2/10	SNAP2/2.2/20
2.3	2.8	2.25	3.0	SNAP2/2.3/10	SNAP2/2.3/20
2.4	2.8	2.35	3.0	SNAP2/2.4/10	SNAP2/2.4/20
2.5	3.0	2.45	3.2	SNAP2/2.5/10	SNAP2/2.5/20
2.6	3.0	2.55	3.2	SNAP2/2.6/10	SNAP2/2.6/20
2.7	3.2	2.65	3.4	SNAP2/2.7/10	SNAP2/2.7/20
2.8	3.2	2.75	3.4	SNAP2/2.8/10	SNAP2/2.8/20
2.9	3.4	2.85	3.6	SNAP2/2.9/10	SNAP2/2.9/20

Spare parts		
Pos	Description	Order No.
1	Tool body	GH-Q-G-5024
	Tool body Assembly (incl. Eccentric cam GH-S-E-0031, Roll pin GH-C-E-0811)	GH-Q-G-5025
2	Blade housing	see following page
3	Control bolt	see following page
4	spring	GH-H-F-0047
5	Clamping screw M3x3.3	GH-H-S-1075
6	Set screw M4x5 DIN913	GH-H-S-0134
7	Eccentric cam	GH-S-E-0031
8	Roll pin	GH-C-E-0811
9	Blade	see following page

Blade housing pos. 2		
Tool reference no.	Blade housing order no.	
	NL 10mm	NL 20mm
SNAP2/2.0/...	GH-Q-N-0001	GH-Q-N-0061
SNAP2/2.1/...	GH-Q-N-0002	GH-Q-N-0062
SNAP2/2.2/...	GH-Q-N-0003	GH-Q-N-0063
SNAP2/2.3/...	GH-Q-N-0004	GH-Q-N-0064
SNAP2/2.4/...	GH-Q-N-0005	GH-Q-N-0065
SNAP2/2.5/...	GH-Q-N-0006	GH-Q-N-0066
SNAP2/2.6/...	GH-Q-N-0007	GH-Q-N-0067
SNAP2/2.7/...	GH-Q-N-0008	GH-Q-N-0068
SNAP2/2.8/...	GH-Q-N-0009	GH-Q-N-0069
SNAP2/2.9/...	GH-Q-N-0010	GH-Q-N-0070

Control Bolt pos. 3		
	NL 10mm	NL 20mm
Order no.	GH-Q-E-0236	GH-Q-E-0237

SNAP2 blade GS 90° geometry pos. 9						
cham fer-ø	front and back cutting		back cutting only		Dimension	
	D	TiAlN	DLC	TiAlN	DLC	A
2.4	GH-Q-M-40031	GH-Q-M-40032	GH-Q-M-40631	GH-Q-M-40632	6.6	0.53
2.6	GH-Q-M-40051	GH-Q-M-40052	GH-Q-M-40651	GH-Q-M-40652	6.7	0.57
2.8	GH-Q-M-40071	GH-Q-M-40072	GH-Q-M-40671	GH-Q-M-40672	6.8	0.62
3.0	GH-Q-M-40091	GH-Q-M-40092	GH-Q-M-40691	GH-Q-M-40692	6.9	0.62
3.2	GH-Q-M-40111	GH-Q-M-40112	GH-Q-M-40711	GH-Q-M-40712	7.0	0.62
3.4	GH-Q-M-40131	GH-Q-M-40132	GH-Q-M-40731	GH-Q-M-40732	7.1	0.62

from stock / non-stock item with extended delivery time
others sizes, coatings and types available on request

SNAP3 tool $\varnothing 3.0\text{mm}$ to 3.9mm

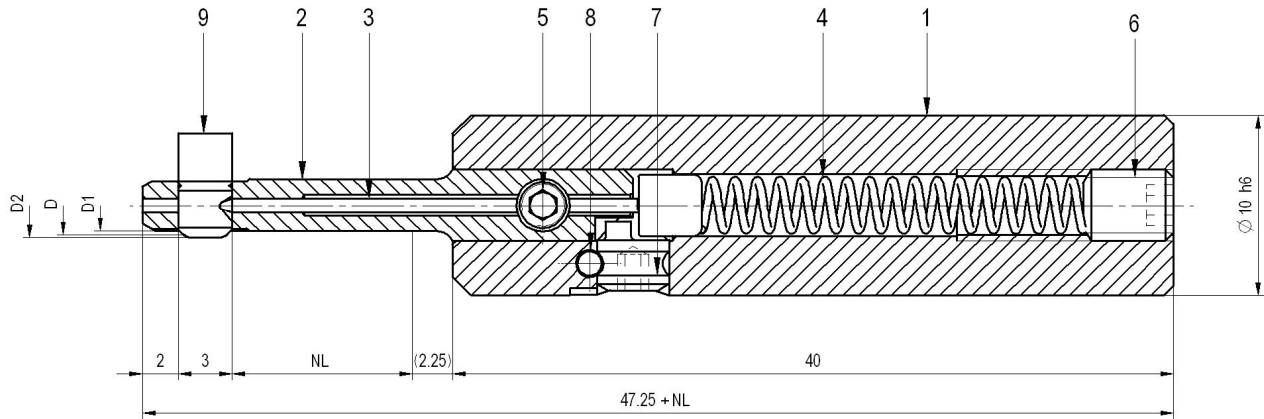

Tool table

Bore- \varnothing d	max chamfer- \varnothing D	Tool- \varnothing D1	Maximal- \varnothing D2	complete tool without blade		
				NL 10mm	NL 20mm	NL 30mm
3.0	3.6	2.9	3.9	SNAP3/3.0/10	SNAP3/3.0/20	SNAP3/3.0/30
3.1	3.9	3.0	4.2	SNAP3/3.1/10	SNAP3/3.1/20	SNAP3/3.1/30
3.2	3.9	3.1	4.2	SNAP3/3.2/10	SNAP3/3.2/20	SNAP3/3.2/30
3.3	4.2	3.2	4.5	SNAP3/3.3/10	SNAP3/3.3/20	SNAP3/3.3/30
3.4	4.2	3.3	4.5	SNAP3/3.4/10	SNAP3/3.4/20	SNAP3/3.4/30
3.5	4.2	3.4	4.5	SNAP3/3.5/10	SNAP3/3.5/20	SNAP3/3.5/30
3.6	4.5	3.5	4.8	SNAP3/3.6/10	SNAP3/3.6/20	SNAP3/3.6/30
3.7	4.5	3.6	4.8	SNAP3/3.7/10	SNAP3/3.7/20	SNAP3/3.7/30
3.8	4.5	3.7	4.8	SNAP3/3.8/10	SNAP3/3.8/20	SNAP3/3.8/30
3.9	4.8	3.8	5.1	SNAP3/3.9/10	SNAP3/3.9/20	SNAP3/3.9/30

Spare parts

Pos	Description	Order no.
1	Tool body	GH-Q-G-5024
	Tool body assembly (incl. Eccentric cam GH-S-E-0031, Roll pin GH-C-E-0811)	GH-Q-G-5025
2	Blade housing	see following page
3	Control bolt	see following page
4	spring	GH-H-F-0047
5	Clamping screw M3x3.3	GH-H-S-1075
6	Set screw M4x5 DIN913	GH-H-S-0134
7	Eccentric cam	GH-S-E-0031
8	Roll pin	GH-C-E-0811
9	Blade	see following page

Blade housing pos. 2			
Tool reference no.	Blade housing order no.		
	NL 10	NL 20	NL 30
SNAP3/3.0/...	GH-Q-N-0021	GH-Q-N-0081	GH-Q-N-0141
SNAP3/3.1/...	GH-Q-N-0022	GH-Q-N-0082	GH-Q-N-0142
SNAP3/3.2/...	GH-Q-N-0023	GH-Q-N-0083	GH-Q-N-0143
SNAP3/3.3/...	GH-Q-N-0024	GH-Q-N-0084	GH-Q-N-0144
SNAP3/3.4/...	GH-Q-N-0025	GH-Q-N-0085	GH-Q-N-0145
SNAP3/3.5/...	GH-Q-N-0026	GH-Q-N-0086	GH-Q-N-0146
SNAP3/3.6/...	GH-Q-N-0027	GH-Q-N-0087	GH-Q-N-0147
SNAP3/3.7/...	GH-Q-N-0028	GH-Q-N-0088	GH-Q-N-0148
SNAP3/3.8/...	GH-Q-N-0029	GH-Q-N-0089	GH-Q-N-0149
SNAP3/3.9/...	GH-Q-N-0030	GH-Q-N-0090	GH-Q-N-0150

Control bolt pos. 3			
	NL 10mm	NL 20mm	NL 30mm
Bestell Nr.	GH-Q-E-0236	GH-Q-E-0237	GH-Q-E-0238

SNAP3 blade GS 90° geometry pos. 9						
cham fer-ø	front and back cutting		back cutting only		Dimension	
	D	TiAlN	DLC	TiAlN	DLC	A
3.3	GH-Q-M-40171	GH-Q-M-40172	GH-Q-M-40771	GH-Q-M-40772	7.1	0.55
3.6	GH-Q-M-40201	GH-Q-M-40202	GH-Q-M-40801	GH-Q-M-40802	7.2	0.70
3.9	GH-Q-M-40231	GH-Q-M-40232	GH-Q-M-40831	GH-Q-M-40832	7.4	0.85
4.2	GH-Q-M-40261	GH-Q-M-40262	GH-Q-M-40861	GH-Q-M-40862	7.5	0.9
4.5	GH-Q-M-40291	GH-Q-M-40292	GH-Q-M-40891	GH-Q-M-40892	7.7	0.9
4.8	GH-Q-M-40321	GH-Q-M-40322	GH-Q-M-40921	GH-Q-M-40922	7.8	0.9

from stock / non-stock item with extended delivery time
 others sizes, coatings and types available on request

SNAP4 tool $\varnothing 4.0\text{mm}$ to 5.0mm

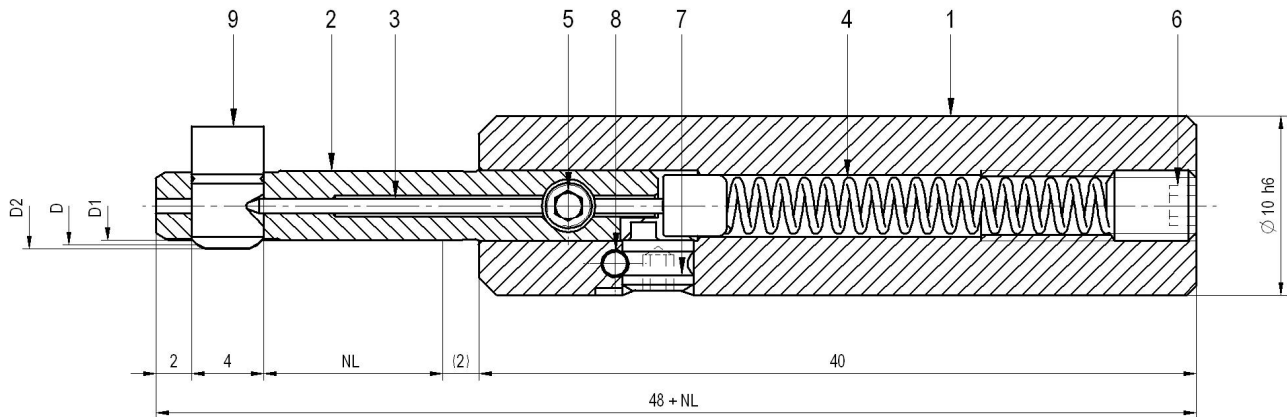

Tool table						
Bore- \varnothing	max chamfer- \varnothing	Tool- \varnothing	Maximal- \varnothing	complete tool without blade		
d	D	D1	D2	NL 10mm	NL 20mm	NL 30mm
4.0	5.2	3.9	5.6	SNAP4/4.0/10	SNAP4/4.0/20	SNAP4/4.0/30
4.1	5.6	4.0	6.0	SNAP4/4.1/10	SNAP4/4.1/20	SNAP4/4.1/30
4.2	5.6	4.1	6.0	SNAP4/4.2/10	SNAP4/4.2/20	SNAP4/4.2/30
4.3	5.6	4.2	6.0	SNAP4/4.3/10	SNAP4/4.3/20	SNAP4/4.3/30
4.4	5.6	4.3	6.0	SNAP4/4.4/10	SNAP4/4.4/20	SNAP4/4.4/30
4.5	6.0	4.4	6.4	SNAP4/4.5/10	SNAP4/4.5/20	SNAP4/4.5/30
4.6	6.0	4.5	6.4	SNAP4/4.6/10	SNAP4/4.6/20	SNAP4/4.6/30
4.7	6.0	4.6	6.4	SNAP4/4.7/10	SNAP4/4.7/20	SNAP4/4.7/30
4.8	6.0	4.7	6.4	SNAP4/4.8/10	SNAP4/4.8/20	SNAP4/4.8/30
4.9	6.4	4.8	6.8	SNAP4/4.9/10	SNAP4/4.9/20	SNAP4/4.9/30
5.0	6.4	4.9	6.8	SNAP4/5.0/10	SNAP4/5.0/20	SNAP4/5.0/30

Spare parts		
Pos	Description	Order no.
1	Tool body	GH-Q-G-5024
	Tool body assembly (incl. Eccentric cam GH-S-E-0031, Roll pin GH-C-E-0811)	GH-Q-G-5025
2	Blade housing	see following page
3	Control bolt	see following page
4	spring	GH-H-F-0047
5	Clamping screw M3x3.3	GH-H-S-1075
6	Set screw M4x5 DIN913	GH-H-S-0134
7	Eccentric cam	GH-S-E-0031
8	Roll pin	GH-C-E-0811
9	Blade	see following page

Blade housing pos. 2			
Tool reference no.	Blade housing order no.		
	NL 10	NL 20	NL 30
SNAP4/4.0/...	GH-Q-N-0041	GH-Q-N-0101	GH-Q-N-0161
SNAP4/4.1/...	GH-Q-N-0042	GH-Q-N-0102	GH-Q-N-0162
SNAP4/4.2/...	GH-Q-N-0043	GH-Q-N-0103	GH-Q-N-0163
SNAP4/4.3/...	GH-Q-N-0044	GH-Q-N-0104	GH-Q-N-0164
SNAP4/4.4/...	GH-Q-N-0045	GH-Q-N-0105	GH-Q-N-0165
SNAP4/4.5/...	GH-Q-N-0046	GH-Q-N-0106	GH-Q-N-0166
SNAP4/4.6/...	GH-Q-N-0047	GH-Q-N-0107	GH-Q-N-0167
SNAP4/4.7/...	GH-Q-N-0048	GH-Q-N-0108	GH-Q-N-0168
SNAP4/4.8/...	GH-Q-N-0049	GH-Q-N-0109	GH-Q-N-0169
SNAP4/4.9/...	GH-Q-N-0050	GH-Q-N-0110	GH-Q-N-0170
SNAP4/5.0/...	GH-Q-N-0051	GH-Q-N-0111	GH-Q-N-0171

Control bolt pos. 3			
	NL 10mm	NL 20mm	NL 30mm
Bestell Nr.	GH-Q-E-0236	GH-Q-E-0237	GH-Q-E-0238

SNAP4 blade GS 90° geometry pos. 9						
cham fer-ø	front and back cutting		back cutting only		Dimension	
	D	TiAlN	DLC	TiAlN	DLC	A
4.4	GH-Q-M-40381	GH-Q-M-40382	GH-Q-M-40981	GH-Q-M-40982	7.7	0.65
4.8	GH-Q-M-40421	GH-Q-M-40422	GH-Q-M-41021	GH-Q-M-41022	7.9	0.85
5.2	GH-Q-M-40461	GH-Q-M-40462	GH-Q-M-41061	GH-Q-M-41062	8.1	1.05
5.6	GH-Q-M-40501	GH-Q-M-40502	GH-Q-M-41101	GH-Q-M-41102	8.3	1.20
6.0	GH-Q-M-40541	GH-Q-M-40542	GH-Q-M-41141	GH-Q-M-41142	8.5	1.20
6.4	GH-Q-M-40581	GH-Q-M-40582	GH-Q-M-41181	GH-Q-M-41182	8.7	1.20

from stock / non-stock item with extended delivery time
others sizes, coatings and types available on request

SNAP2 / 3 Tool for Thread M2.5 / M3 / M4

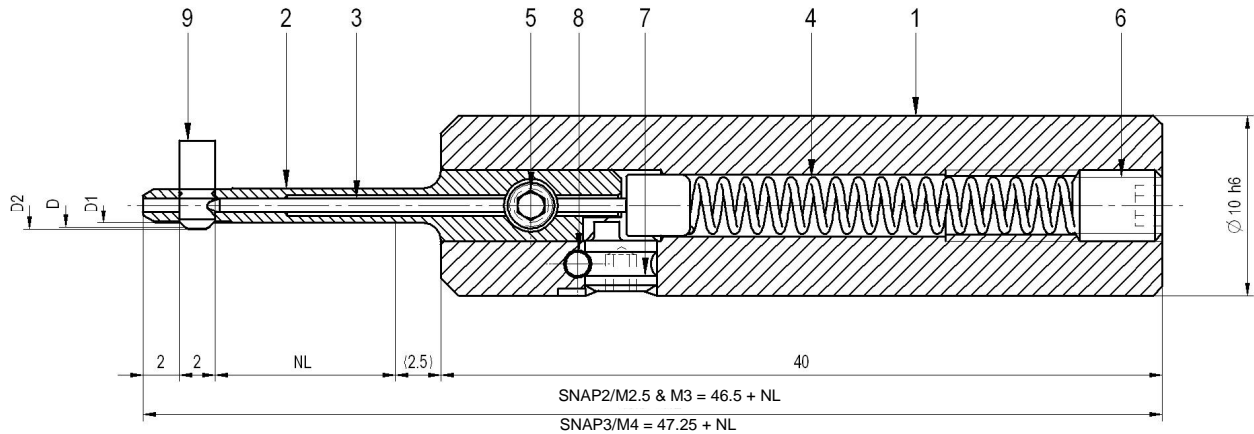

Tool table						
Bore- \varnothing	max chamfer- \varnothing	Tool- \varnothing	Maximal- \varnothing	complete tool without blade		
d	D	D1	D2	NL 10mm	NL 20mm	NL 30mm
M2.5(\varnothing 2.05)	2.8	2.0	3.0	SNAP2/M2.5/10	SNAP2/M2.5/20	
M3(\varnothing 2.5)	3.4	2.45	3.6	SNAP2/M3/10	SNAP2/M3/20	
M4(\varnothing 3.3)	4.5	3.2	4.8	SNAP3/M4/10	SNAP3/M4/20	SNAP3/M4/30

Spare parts		
Pos	Description	Order no.
1	Tool body	GH-Q-G-5024
	Tool body assembly (incl. Eccentric cam GH-S-E-0031, Roll pin GH-C-E-0811)	GH-Q-G-5025
2	Blade housing	see following page
3	Control bolt	see following page
4	spring	GH-H-F-0047
5	Clamping screw M3x3.3	GH-H-S-1075
6	Set screw M4x5 DIN913	GH-H-S-0134
7	Eccentric cam	GH-S-E-0031
8	Roll pin	GH-C-E-0811
9	Blade	see following page

Blade housing pos. 2			
Tool reference no.	Blade housing order no..		
	NL 10mm	NL 20mm	NL 30mm
SNAP2/M2.5/...	GH-Q-N-0015	GH-Q-N-0075	
SNAP2/M3/...	GH-Q-N-0016	GH-Q-N-0076	
SNAP3/M4/...	GH-Q-N-0035	GH-Q-N-0095	GH-Q-N-0155

Control bolt pos. 3			
Tool reference no.	Control bolt order no.		
	NL 10mm	NL 20mm	NL 30mm
SNAP2/M2.5/...	GH-Q-E-0254	GH-Q-E-0256	
SNAP2/M3/...	GH-Q-E-0236	GH-Q-E-0237	
SNAP3/M4/...	GH-Q-E-0236	GH-Q-E-0237	GH-Q-E-0238

SNAP2/3 thread blades GS 90° geometry pos. 9						
chamfer- ϕ	front and back cutting		back cutting only		Dimension	
	D	TiAlN *	DLC	TiAlN	DLC	A
M2.5 ϕ 2.8	GH-Q-M-41501	GH-Q-M-41502	GH-Q-M-41601	GH-Q-M-41602	6.8	0.62
M3 ϕ 3.4	GH-Q-M-41511	GH-Q-M-41512	GH-Q-M-41611	GH-Q-M-41612	7.1	0.62
M4 ϕ 4.5	GH-Q-M-41521	GH-Q-M-41522	GH-Q-M-41621	GH-Q-M-41622	7.7	0.9





from stock / non-stock item with extended delivery time
others sizes, coatings and types available on request

SNAP2/3/4 Cutting data

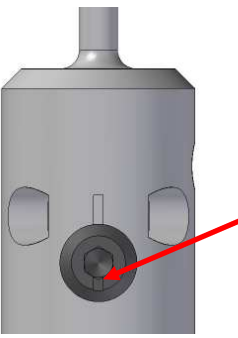
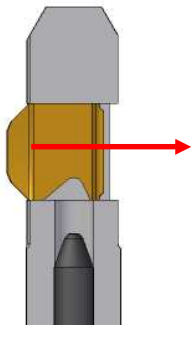
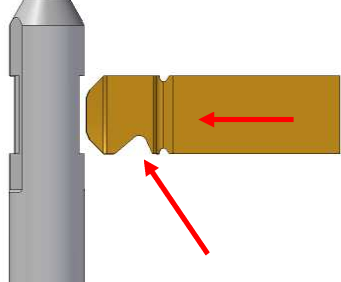
Cutting data		
Material	Speed	Feed
	Vc. (m / min.)	F (mm / rev.)
Unalloyed steel up to 500N/mm ²	30 - 70	0.02 - 0.1
Low alloyed steel 500-950N/mm ²	30 - 70	0.02 - 0.1
Alloyed steel above 950N/mm ²	30 - 60	0.02 - 0.08
Stainless steel	20 - 50	0.02 - 0.05
Grey cast iron	30 - 80	0.02 - 0.1
Aluminium	40 - 80	0.05 - 0.13

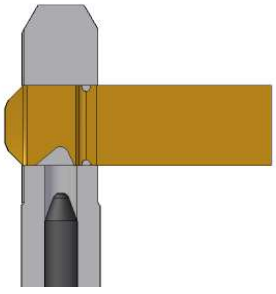
SNAP2/3/4 blade change

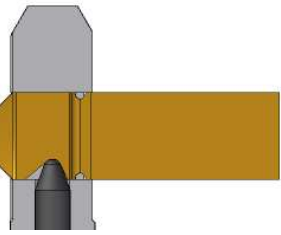
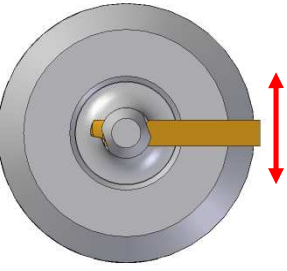
	<p>Initial situation:</p> <p>Tool with SNAP2 blade assembled.</p>
	<p>Turn eccentric screw 180° until the notch points away from the blade housing. (backwards or downwards)</p>
	<p>By turning the eccentric screw the leading pin is pulled backwards out of the pin groove of the blade, hence the blade can be pushed out in arrow direction.</p>
	<p>By assembly a new blade (blade with integrated assembly aid) watch that entering with the blade cutting side ahead from the blade housing side having no chip clearance.</p>

	<p>The blade with integrated assembly aid must be slid in so far until the pin groove of the blade is located over the pin cross hole. As optical assistance watch that the SNAP2 cutting edge sticks out completely on the blade housing side having the chip clearance.</p>
	<p>Back off the eccentric screw 180° until the notch points again in blade housing direction. (in front or up)</p>
	<p>By turning back the eccentric screw the leading pin is pushed back into the pin groove of the blade.</p>
	<p>To remove the blade assembly aid put back the blade with integrated assembly aid approx. 0.4mm with the finger until the predetermined breaking point is located at the position of the blade window. Afterwards the assembly aid (overhanging part) has to be broken off with the thumb and the forefinger clockwise or counter-clockwise. By releasing the blade it moves in the initial position.</p>
	<p>End position:</p> <p>Tool with SNAP2 blade assembled.</p>



One Operation.

HEULE tools for front and back machining of bore edges in one single pass.

Deburring

- COFA
- SNAP

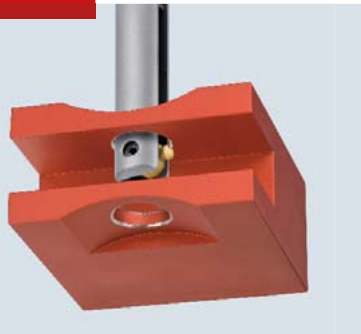

Chamfering

- SNAP
- GH-S
- DEFA

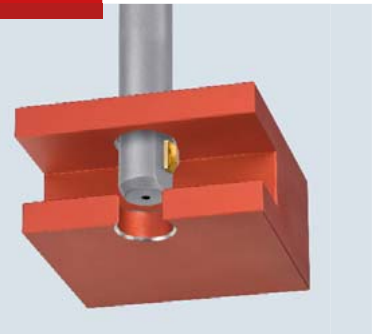

Countersinking

- SOLO
- GH-Z/E
- GH-K



Drilling

- VEX-P
- VEX-S



HEULE+
PRECISION TOOLS

HEULE WERKZEUG AG
Wegenstrasse 11/Postfach
9436 Balgach
Switzerland

Telefon +41 71 7263838
Telefax +41 71 7263839
info@heule.com
www.heule.com

HEULE TOOL CORPORATION
4722 A Interstate Drive
Cincinnati, Ohio 45246
USA

Phone +1 513 8609900
Fax +1 513 8609992
info@heuletool.com
www.heuletool.com

HEULE WERKZEUG AG
China Rep. Office
Room 1711, Gelunbu Plaza
No. 291 Guangyi Road
214000 Wuxi, Jiangsu
China

Phone +86 510 88882266
Fax +86 510 82797040
china@heule.com
www.heule.com