

Industry	Automobile
Work piece	Connecting rod
Material	Steel
What is machined	Spotfacing backward for the head of the fixing screws. Interrupted cut at the beginning of the spotfacing operation.

Sketch of work piece

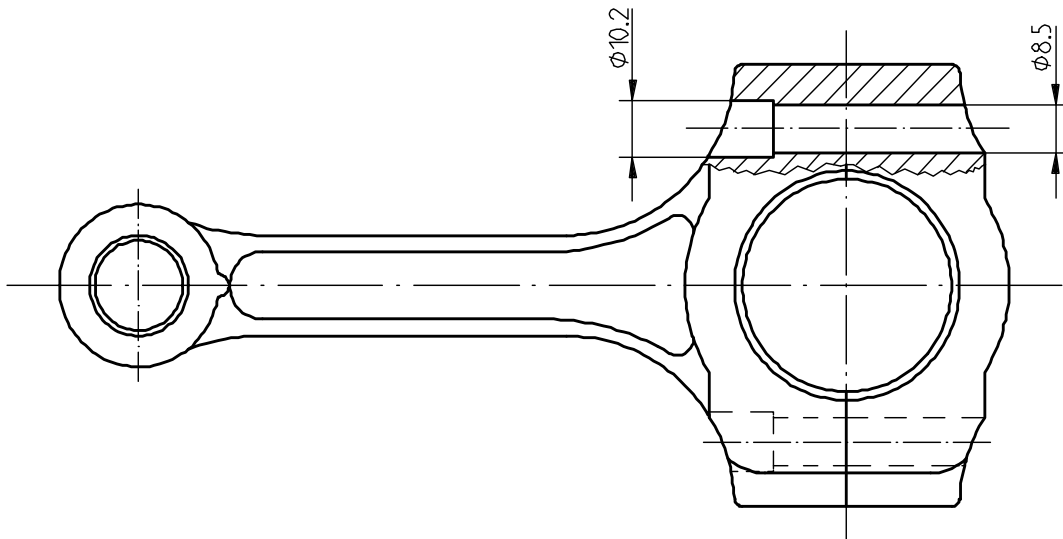

Sketch of tool and work piece

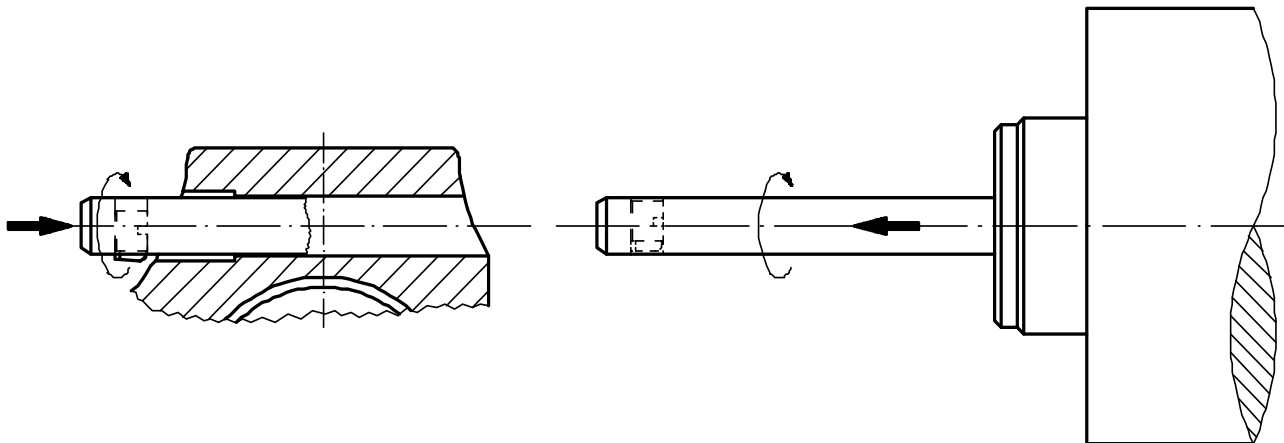

Tool	SOLO 8.5-10.2/100
Speed	1'000 1/min
Feed	0.05 rev/U
Coolant	Emulsion
Notes	In one single work operation without reversing the spindle.